



MODULE 2 – SHORING
PART A - SHORING BASICS
*Urban Search & Rescue Shoring
Training For
The Rescue Specialist*

Slide No. 1

Terminal Objectives



- *The Student shall learn how to maintain the integrity of all structurally unstable elements*
- *The Student shall learn how to properly transmit or redirect the collapse loads to stable ground or other suitable structural elements capable of handling the additional loads*

- This slide will describe the purpose of the shoring lecture.
- Briefly describe each bullet point as it pertains to the lecture
- Give a general example of each of the bullet points.

Slide No. 2

Enabling Objectives



- *have a basic understanding of how to conduct a proper shoring size-up*
- *be able to identify locations for proper shoring placement*
- *understand the shoring team concept and identify positions & purpose*
- *understand the different types of shoring components and equipment*

- This slide will describe the purpose of the shoring lecture.
- Briefly describe each bullet point as it pertains to the lecture
- Give general example of each of the bullet points.

Slide No. 3

HAZARD MITIGATION



- **AVOID IT** - *prevent access to the hazardous area*
- **REMOVE IT** - *pull down cracked and leaning chimney*
- **SHORE IT** - *construct a shoring system*
- **MONITOR IT** - *set up warning system & escape plan*

- Four main options open to you
- **Avoid**- if there is no one there don't get tied up in unnecessary shoring operations.
- **Remove**- Many times the structural damage is beyond our normal capability; it can be much easier and safer to have the hazard removed instead of a complicated and lengthy shoring ops.
- **Shore**- to rescue trapped victims, many times shoring of the local area will be necessary. Do it properly
- **Monitor**- set up transit and watch for movement, have a way out

Slide No. 4

Place Barrier tape to Avoid



- If there is no life hazard or structural hazard to the rescuers then avoid the area, you don't need unnecessary work.

Slide No. 5



Remove
Chimney by
pulling it
away from
house

- Don't waste time shoring damaged masonry if at all possible.
- It is very difficult to shore cracked masonry properly, and further movement could cause a collapse.

Slide No. 6

Shore leaning walls prior to Entry



- Rakers must be erected in pairs in order to be stable.

Slide No. 7

**WE INSTALL
RESCUE
SHORING TO
PROTECT
"US"**



- The bottom line is we put the shoring in place for ourselves to work safely in a damaged structure.
- You better install it the right way, if it fails the ones that will be hurt will be yourself and your fellow rescuers!
- Shoring failure is not an option, there are no excuses for it.
- Disaster will be the only result.

Slide No. 8

SHORING SIZE-UP



- *identify structural hazards, damage and potential victim locations*
- *determine best method to mitigate the hazard and damage*
- *determine the type & placement of shoring systems in relation to structural hazards and potential victim location*

- Size up is the most important item to determine the positioning and size of your shoring systems.
- Describe each bullet point in detail.
- Give example of each item.

Slide No. 9

SIZE-UP Cont.



- *performed by at least a structural specialist, rescue team manager and or a rescue squad officer*
- *it must be extensive, accurate and continue throughout the rescue operation*

- Stress the importance of cooperation between team members.
- Explain the size up only ends when the rescue operation ends.

Slide No. 10

SIZE-UP CONSIDERATIONS



- **VICTIMS**
- **SIX SIDED APPROACH**
- **STRUCTURAL ELEMENTS**
- **AGE & CONDITON OF THE STRUCTURE**
- **COLLAPSE WARNING SIGNS**

- Placement of the shores is extremely important, this must be explained to the students.
- Identify and discuss each bullet point thoroughly.
- It is critical the shores are erected in the right position.

Slide No. 11

PLACEMENT



ALL SHORING OPERATIONS IN WOOD & STEEL FRAMED STRUCTURES SHOULD BE STARTED AT LEAST 1 FLOOR BELOW AND IN CONCRETE STRUCTURES AT LEAST 2 FLOORS BELOW THE LEVEL OF ANY DAMAGE

- This rule of thumb works in many cases.
- One item that must also be considered is the amount of debris on these floors.
- This is a guide line only, all situations must be carefully examined and calculated.

Slide No. 12

SHORING **PLACEMENT**



- SUPPORT UNSTABLE STRUCTURAL ELEMENTS
- UNDER MAIN DEBRIS PILE
- UNDER VICTIM LOCATION

- These are 3 primary locations that your shoring may be installed in.
- Look at these locations first.
- This is part of your size-up.
- After shoring is installed, it must be constantly checked for possible movement.

Slide No. 13



Support 2nd Floor Beam, so that it can continue to provide lateral support for column

Slide No. 14

Need Shoring for wood floor under this URM rubble that fell from above



SHORING **PLACEMENT**



- SHORES TO BEAR ON EACH OTHER
- FROM THE OUTSIDE IN
- TEAM ACCESS & EGRESS

- Keep your shoring elements in line with each other when erecting in a multistory situation. The loads from above must be evenly and directly distributed through all the shores.
- Protect yourself at all times, shore from the good area into the bad, don't start from the most unstable area first.
- Do not cut off the access of personnel and equipment, on occasion shores may have to be constructed around your teams access points.

Slide No. 15



**Support wood roof
and floor with
aligned vertical
shores**



Slide No. 17



Reinforce access w/shoring

Slide No. 18



**Provide horizontal
shoring in access
corridor**



•Pneumatic shores can be used to good advantage in rescue shoring, they go in quickly and are easy to adjust.

Slide No. 19

**MISSING STRUCTURAL
SUPPORTS**

**BEAMS
COLUMNS
GIRDERS
ARCHES**



- Each one of these structural items supports other structural elements.
- If any of these items fails or is missing, some sort of collapse will occur.
- Their presence must be detected as soon as possible, and their structural integrity must be ascertained immediately.
- If compromised, the decision must be made on the possibility of replacement shoring being constructed.

Slide No. 20

The SHORING SQUAD

<u>SHORING TEAM</u>	<u>CUTTING TEAM</u>
SHORING OFFICER	LAYOUT FF
MEASURING FF	CUTTING FF
SHORING FF	TOOL & EQUIP FF

- The rescue specialist squad is broken up into 2 teams.
- Each man has an assignment; however do to the nature of collapse rescue, all these assignments are flexible.
- Explain each assignment and how the positions all interact with each other.
- It is a team effort, always.

Slide No. 21

SHORE ASSEMBLY TEAM CUTTING TEAM

SHORING OIC	CUTTING TEAM OIC
MEASURING FF	LAYOUT FF
SHORING FF	FEEDER
SHORING FF	CUTTING FF
SAFETY FF	TOOL & EQ FF
RUNNER	RUNNER

- This setup is for extensive operations where multiple teams will be utilized.
- Team positions are similar with additional manpower for the movement of material.
- In a typical operation you will need the use of one cutting team for every two to three shoring teams.
- It will depend on the location of the cutting station to the shoring, and on the accessibility of the damaged areas to the shoring teams.

Slide No. 22

THE "T" SHORE

INITIAL SAFETY SHORE
STANDARD "T"
TEMPORARY SHORING
MAXIMUM HEADER LENGTH = 3'

- Utilize as a safety shore only.
- Cannot be relied upon as a permanent shore system.
- Remember; this shore is unstable.
- Header length of 3 ft; need a 12x12 gusset plate.
- Header length of 4 ft need an 18x18 gusset plate.

Slide No. 23

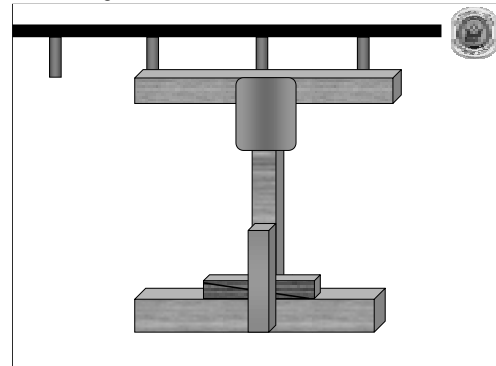

- Explain the step by step erection of the T shore.
- Explain the proper nail pattern for both size gusset plates.
- Explain the proper positioning of the t post under the floor beams.
- Explain the sole plate positioning in relation to the header.

Slide No. 24



Slide No. 25

VERTICAL SHORE

**RESUPPORT UNSTABLE
FLOORS OR ROOFS
POSTS UNDER FLOOR BEAMS
MID-POINT BRACING AT
9 ft CEILING HEIGHT**

- This shore will be erected 90 percent of the time.
- Typically constructed of 4x4's.
- Explain the reason for the cross bracing and lateral strength.

Slide No. 26

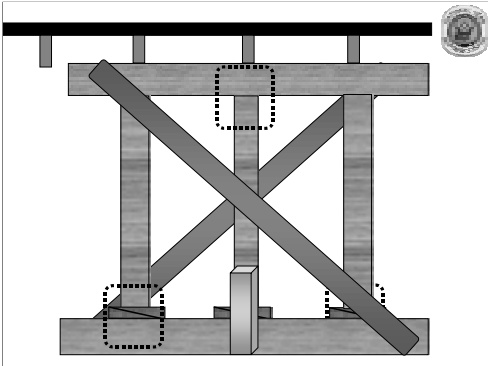

- Explain step by step erection of the shores.
- Reinforce the need for the cross braces and the min. capacity 2% of total load.
- Explain the need for the 5 nail pattern.
- Overhang the header and sole plate 12" on both ends.
- Cross braces must be carefully positioned & anchored to the header and the sole plate to be effective. See next slide

Slide No. 27

DIAGONAL BRACE JOINT

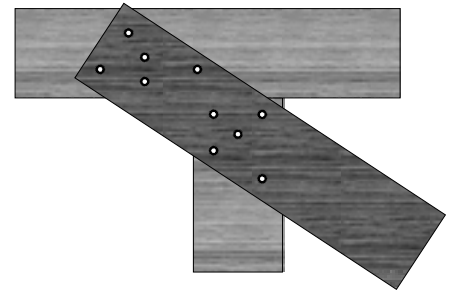

- Overlap the end post one foot.
- Anchor the diagonal cross brace as shown, for the most effective bracing strength.

Slide No. 28



Slide No. 29

HORIZONTAL SHORE

STABILIZE PASSAGEWAYS

2 - 3 SUPPORT STRUTS

**DEBRIS WEIGHT WILL
DETERMINE THE SIZE
AND # OF STRUTS NEEDED**

- Used to brace walls that are compromised.
- Uses opposite wall as support.
- Used mainly is larger structures with concrete or masonry walls.

Slide No. 30

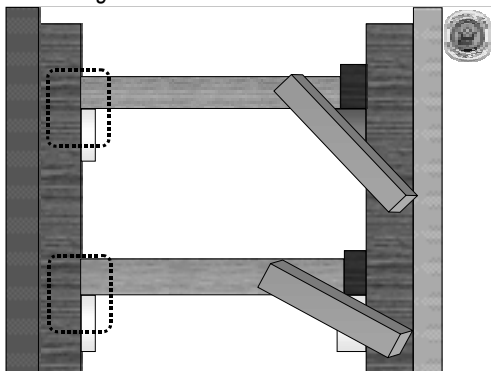

- Install shoring square, pad out wall plates if necessary.
- struts must have full contact with walls.
- Place wedges on good wall then pressurize.
- Install cleats under each post, on both sides.
- Gusset plate if necessary, in earthquake it is required.
- Cross brace if not being used for access.

Slide No. 31



Slide No. 32

THE DOOR SHORE

**RESUPPORT ENTRANCE
SUPPORT WALL BREACH
1 inch THICKNESS FOR
EVERY FOOT of HEADER
LENGTH**

- Similar to the window shore in fabrication.
- Wedge the posts on the bottom at all times, laterally instability will be greater at the top of the shore than at the bottom.
- Anchor to door frame.
- Gusset plate when entrance is being utilized by rescue personnel.
- Stress rule of thumb, 1 inch for every foot, explain options available.

Slide No. 33

The WINDOW SHORE

**STABILIZE WINDOW OPENING
SUPPORT DAMAGED HEADER
1 inch THICKNESS FOR EVERY
FOOT OF HEADER OPENING**

- Similar to the door shore in fabrication
- wedge the posts on the bottom at all times, laterally instability will be greater at the top of the shore than at the bottom.
- Anchor to window frame when possible
- gusset plate when entrance is being utilized by rescue personnel
- stress rule of thumb, 1 inch for every foot, explain options available

Slide No. 34

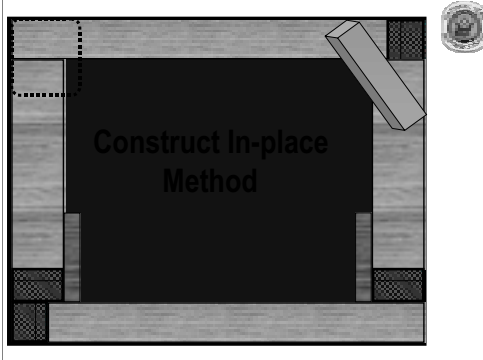

- Describe the step by step proper erection of the shore.
- Reinforce the reasons for the wedges being on the bottom.
- Describe options available with the erection of the shore.
- Mention the minimum bearing of the posts has to be at least 2 inches, describe options.
- Cross brace if not used for access.

Slide No. 35

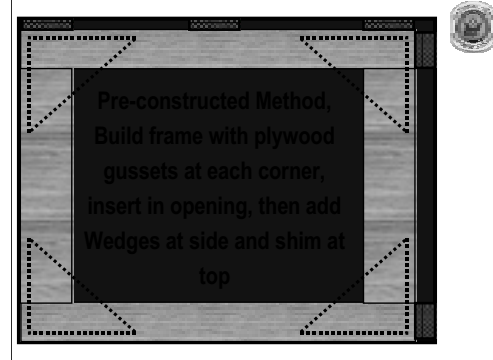

- Describe the step by step proper erection of the shore.
- This alternate method may be used to reduce the risk of building the entire shore in a dangerous opening, such as the one in the following slide.
- This does not work in many situations and it would be just an option.
- You give up some adjustability for greater safety.

Slide No. 36



Window
Shore
In
Masonry
wall



Slide No. 37



How do you
shore this
opening?

First choice
is to avoid it



Slide No. 38

LACED POST SHORE



THE STRONGEST AND STABILIST SHORE WE
CAN ERECT

CAN BE UTILIZED AS A SAFE HAVEN AREA
WHEN NECESSARY

4X4'S & 6X6'S USUAL

ONE MIDPOINT BRACE UP TO 12' HIGH
(2 mid point braces if higher than 12')

5' MAXIMUM POST SPACING

- The strongest shore we can assemble.
- Use 2x4's for bracing of 4x4 posts.
- Use 2x6's for bracing of 6x6 posts.
- When used as safe haven.

Slide No. 39

LACED POST SHORE (up to 12 feet high)

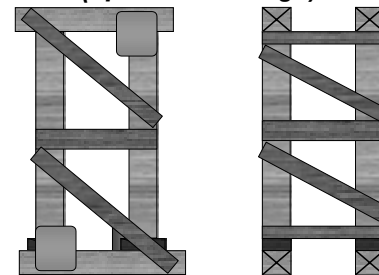

- Explain the step by step erection of the shore.
- Identify each element as it appears on the screen ; header size is 4x6 minimum.
- The over hangs should be 12 inches on the header and sole plates.
- Stress proper fit of diagonal at header & sole.
- Stress the proper nail patterns and the spacing for the bracing.
- Maximum spacing of posts is 5 feet.

Slide No. 40



Slide No. 41

LACED POST SHORE (over 12 feet high)

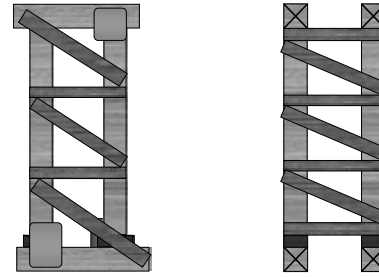

- Explain that you need additional horizontal & diagonal to keep the diagonals from getting too long.
- The diagonals in Laced Posts are limited in length since they resist both tension and compression forces.

Slide No. 42

SLOPED FLOOR SHORE

Used Where Box Cribbing Is Not Practical
Must Be Erected In Pairs And Cross Braced as
for Laced Posts, spacing = 5ft maximum
If need to space over 5 ft, 8 ft max, then need to
Cross Brace same as Raker Shores
Posts Are Erected At Right Angles To The Floor
In Question unless "Friction System" is more
practical.
Minimum of 3 - 1 Inch Pins as Anchors

- Used when the slope of the floor is over 5%.
- When box cribbing is impractical this is the shore to replace it.
- Generally spaced 4 to 5 ft apart.
- Braced at front and back with lacing (similar to Laced Posts).
- If need 6 to 8 ft apart, bracing should be same as for Raker Shores.
- Minimum 2 posts per shore.

Slide No. 43

SLOPED FLOOR SHORE Perpendicular method

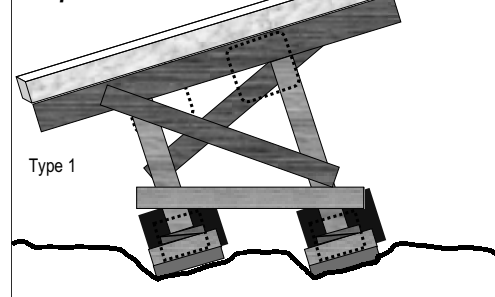

- Use this shore in direct contact with the ground.
- Dig the holes parallel with slope of the floor.
- Make holes approximately 12" deep.
- Use the "U" channel to anchor the base of the shores.
- Explain step by step erection of the shore.
- Re-emphasize the need for the proper nail patterns.

Slide No. 44

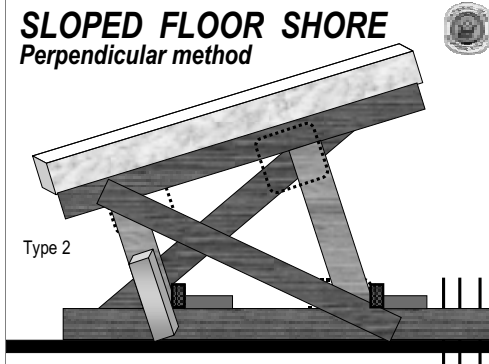

- Explain the step by step erection procedure for the shore.
- The posts are assembled at right angles to the floor to be shored, the force of the load is in that direction.
- Base of posts are constructed similar to raker shores, need wedges and bottom cleats.
- Bottom cleats minimum 24 inches.
- Need 3 anchor pins.

Slide No. 45

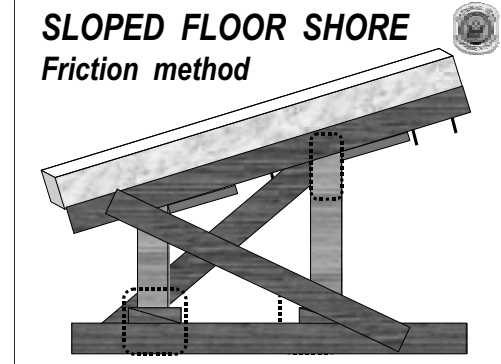

- This shore is utilized when the slab in question is able to move or shift.
- The vertical posts will transfer both sloped and perpendicular forces.

Slide No. 46

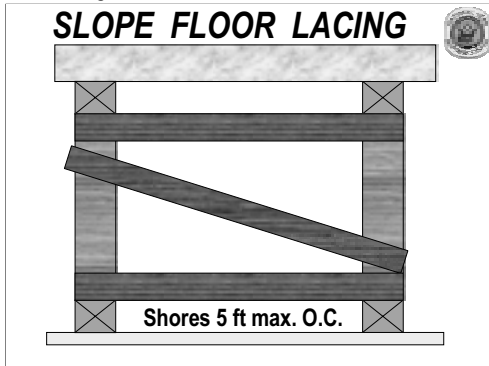

- Two shores must be erected.
- Spacing as necessary, 4 to 5ft maximum.
- Brace with lacing as shown in front and back.
- For spacing over 5 ft use bracing as for Raker Shores, horizontals + X bracing (see 2nd next slide)
- Use 2x6's for all bracing.
- If shore is less than 3 feet high, 3/4" plywood can be used instead, see next slide.

Slide No. 47

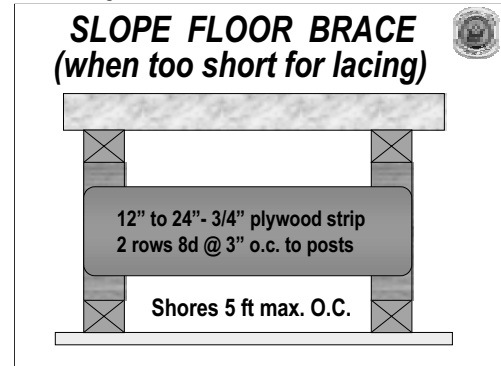

- For spacing up to 5 ft and height less than 4 ft, a 3/4" x 12" to 24" strip of plywood may be used for bracing two sloped floor shores together.
- Maximum distance from edge of plywood to top or bottom of shore should be about 12".

Slide No. 48

SLOPE FLOOR X BRACING

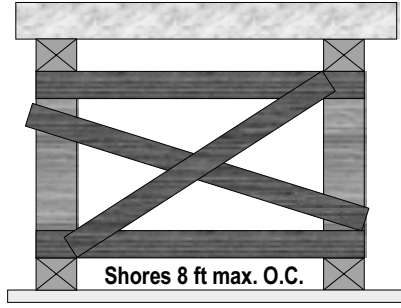

- Two shores must be erected.
- Spacing as necessary, 5 to 8ft maximum.
- Brace with lacing as shown in front and back.
- For spacing 5 ft and less use lacing as in previous slide.
- Use 2x6's for all bracing.

Slide No. 49



Slide No. 50

FLYING RAKER SHORE

**A SAFETY RAKER SHORE
MUST BE ANCHORED TO THE WALL TO
WORK PROPERLY
NOT A PERMANENT SYSTEM!
USE U-CHANNEL FOOT
CAN BE REUSED**

- Initial safety shore only.
- Must be anchored to the wall as well as the ground.
- Can be reused.
- On masonry walls generally place sheet of plywood in front.

Slide No. 51

FLYING RAKER SHORE

(First Option - Pre-Construct)

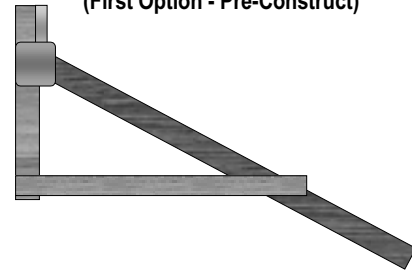

- Explain the step by step procedure for the erection of this shore.
- Explain the shores elements as they appear on screen.
- Generally constructed of 4x4's.
- Must be anchored to the wall before shore is pressurized.

Slide No. 52



**Flying
Raker
shore**

Slide No. 53

"U" CHANNEL

12 x 12 - 3/4" plywood gusset

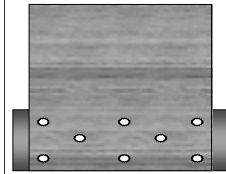

8 - 8d nails, 5 nail pattern

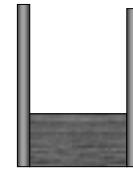

4 x 4 - 18"

- U-channel is standard foot for all shores bearing on soil.
- Use for Sloped Floor shores on earth and Flying + Split Sole Rakers.
- Standard parts = 12" square gusset and 4x4x18".
- Standard nailing is 8d, 5 & 8 in every gusset plate.

Slide No. 54

FLYING RAKER BASE

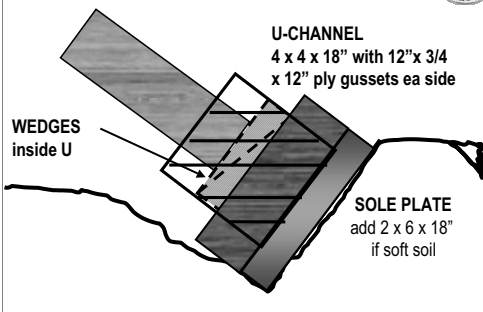

- For Flying Raker just use plain U-channel against earth.
- May add 2x6 or 2x8 under it if you have very poor soil.

Slide No. 55



More of a
cross
between
Flying & Solid
Sole

Slide No. 56

SOLID SOLE RAKER

- The Raker Shore of Choice
- normally erected at 45 degree angle
- used to stabilize leaning walls
- must erect minimum of two and cross brace them
- must be properly constructed to be effective

- Explain the importance of properly erecting this type of shore.
- Must be anchored to the wall and the ground.
- Minimum two shores erected.
- All rakers must be horizontally braced.

Slide No. 57

SOLID SOLE RAKER

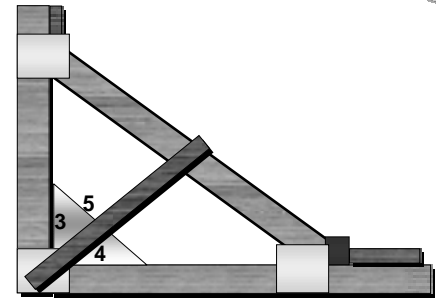

- Explain the proper step by step erection of the shore, and preferred option of pre-constructing away from wall.
- Explain the reasons for the right angle at the base.
- Reinforce the importance of the proper amount of nails as well as the proper nail patterns.
- Identify each component as it appears on the screen.

Slide No. 58



Slide No. 59

SPLIT SOLE RAKER

- Second Option for Raker Shoring
- Generally Utilized in Earth or Where Debris is at the Base of the Wall
- Erected the Same Except for the Base of the Shore
- Can Be Partially Pre-erected Before Installation
- Should be erected at 60 degree angle, whenever possible

- Can be utilized on the earth or solid ground
- generally used in earth situations
- if placed in ground the raker angle should be 60 degrees
- bottom sole plate pieces are 2x6
- placed close to the ground whenever possible
- wall plate must be anchored to the wall before shore is pressurized

Slide No. 60

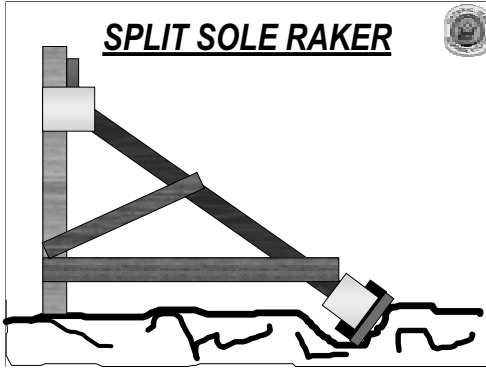

- Explain erection sequence, and preferred option of pre-constructing Rakers away from wall and walk into place.

Slide No. 61

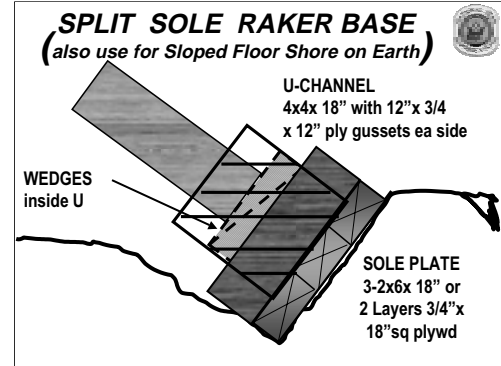

- Add 18" square sole under U-channel to increase capacity of bearing on soil for Split Sole Raker.
- Sole may be 3-2x6x18" or 2 layers of 3/4" plywood nailed together.
- Pre-nail sole to U-channel or toenail U-channel down on top of sole.

Slide No. 62



Slide No. 63



- 3-2x6 Sole in place, make sure lumber lines up and there are no spaces in the back.
- These must be flush with the ground.

Slide No. 64



- U-channel on double layer of 3/4" plywood x 18" square.

Slide No. 65

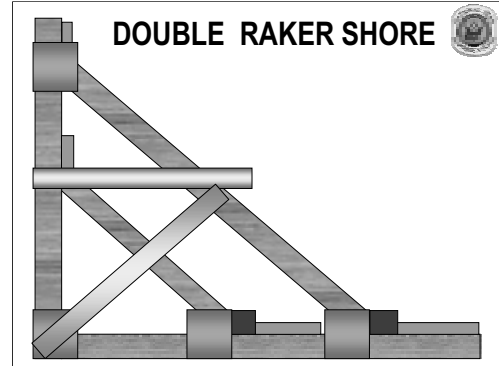

- Discuss assembly and that this is a relatively complicated raker that may be required for 3 story walls.
- May need to splice Raker and wall plate if shores go higher than two stories.

Slide No. 66

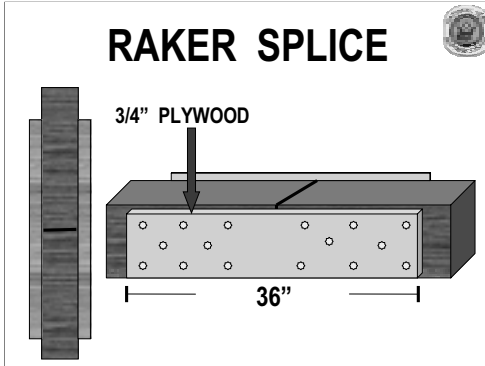

- Typical splice for raker.
- Needs to be done near intersection of raker and mid-point braces, per next slide.

Slide No. 67

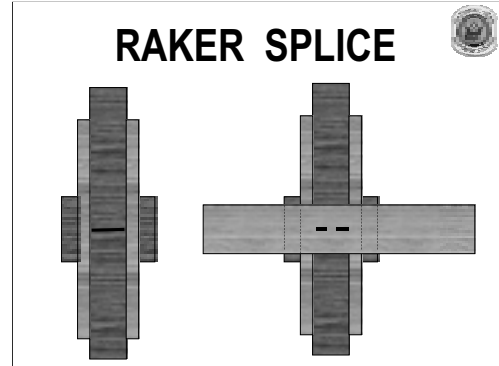

- Splice Raker at intersection.

Slide No. 68

INSERTION POINT

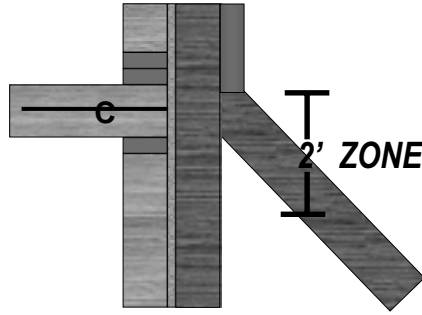

- The proper position for the face of the raker is imperative
- it must be located at the floor level or just below
- a 2 foot range is acceptable
- when calculating the wall insertion point round off to the nearest lowest foot

Slide No. 69

RAKER SHORE ANGLES

DEGREE	PITCH	LENGTH
45 deg	12/12	17
60 deg	12/7	14

- These are the two angles of choice.
- Use the 45 degree angle as first choice.
- The pitch on the framing square is given for both angles.
- The length of the raker per foot of rise is given above, these numbers are consistent for any length.

Slide No. 70

45 DEGREES

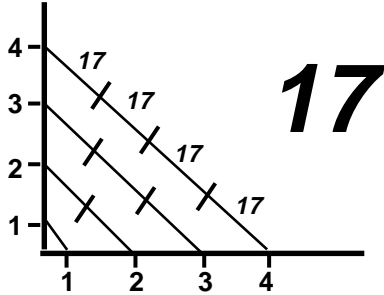

- This graphic explains the reason for the number 17.
- You must explain to the student the principle behind the proper angle use's.
- Give students several raker insertion points and have them calculate the proper raker length.

Slide No. 71

60 DEGREES

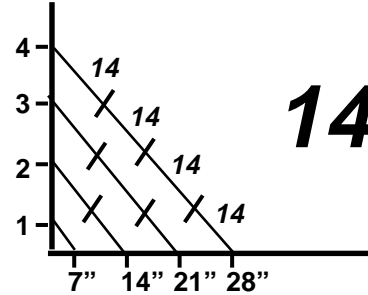

- This graphic explains the reason for the number 14
- you must explain to the student the principle behind the proper angle use's
- give students several raker insertion points and have them calculate the proper raker length

Slide No. 72

"MARRYING" WEDGES

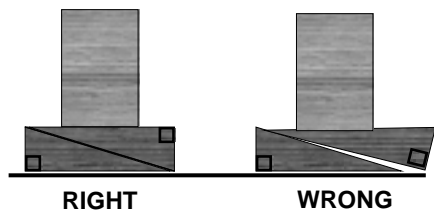

- Bad Marriage, Bad Bearing.
- The right angles must be opposite each other.
- The inclined planes of both wedges must be touching each other.

Slide No. 73

RAKER BRACING SYSTEM

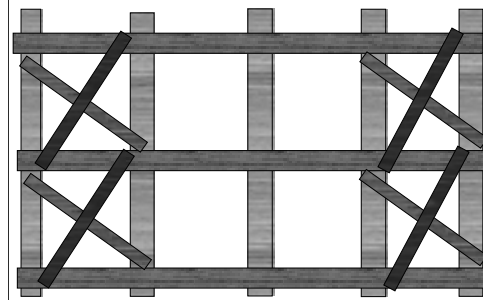

- Should be 2x6 if possible.
- If 2x4's are used, they must be doubled up, side by side.
- Raker insertion point over 8 ft high need three horizontals (for 4x4 Rakers).
- Raker insertion point less than 8ft only need 2 horizontals.
- Both ends must be "X" braced.
- Every third bay needs an "X" brace.
- All bracing should be on the same plane.

Slide No. 74



Slide No. 75



Slide No. 76

NOTCHING

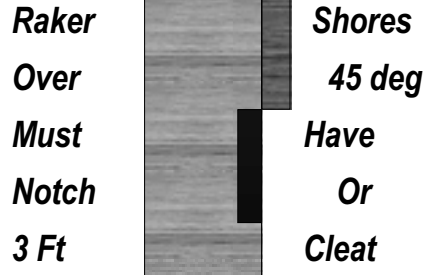

- 45 degree raker shores must have a 24 inch cleat.
- Rakers over 45 degrees need cleats 36 inches long.
- You can place a 1 inch deep notch in the wall plate and use a 24 inch cleat instead.
- 4x4's need an 8 inch long notch.
- 6x's need a 12 inch long notch.

Slide No. 77



Slide No. 78

ANGLE CUTS



- Explain the step by step layout and cutting procedure.
- The 1 1/2 return cut must be at right angles to the face cut.
- The shores length will be measured from tip to tip.
- Explain the importance of the proper cut angles.
- The raker must fit properly in order for the shore to be effective.

Slide No. 79



Slide No. 80

GUSSET PLATES

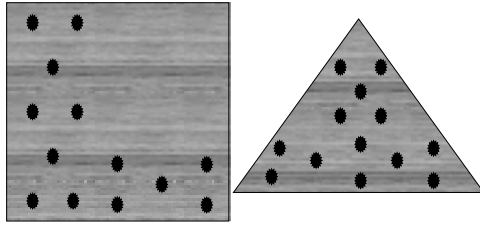

- All plywood must be nailed with 8 penny nails.
- Use the 5 nail pattern method to evenly distribute the nails throughout the plate.
- 5 and 8 in every gusset plate.
- Should normally be 3/4 inch plywood.
- Used on all types of shoring in a earthquake situation.

Slide No. 81

NAIL PATTERNS

The 5 Nail Pattern

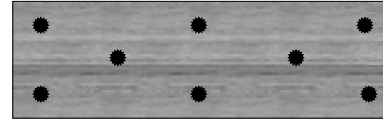

On a 2 x 4

- This nail pattern distributes the nails throughout the material, helping to eliminate splitting.
- Used on all cleats, gusset plates and thrust blocks of any type.
- Should be spaced evenly throughout the material.

Slide No. 82

NAILING

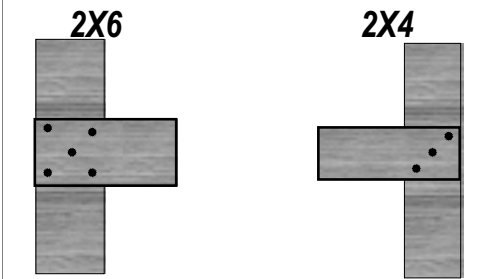

- All nails in dimensional lumber must be 16 penny.
- Rule of thumb; one less nail than the width of the material.
- Space nails properly.
- Keep nails back one inch from the end of the lumber, this will keep splitting to a minimum.

Slide No. 83

ANCHORING SYSTEM

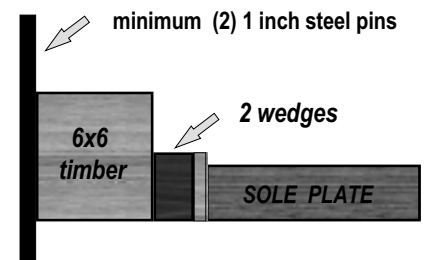

- This is a typical anchoring system, it can be preinstalled before the shore is brought into position.
- 2 -1 inch pins minimum behind each raker (into concrete paving).
- Wedges must be placed between the raker and the anchor block.
- Mention several variations, need additional bearing for solid sole rakers on earth.

Slide No. 84



- Steel thrust block option.
- Anchor the steel down with 6 let in anchors.

Slide No. 85



- Typical method of anchoring, keep the stakes roughly 1 foot apart.
- This method enables a separate crew to install the anchor block before the shores are complete.
- The rakers than can be placed in position, wedged tight and very little time is needed for personnel to be in an unstable area.

Slide No. 86



- Extended sole option.

Slide No. 87



- Bear on a curb or adjacent wall, especially needed if solid sole raker is on earth.

Slide No. 88

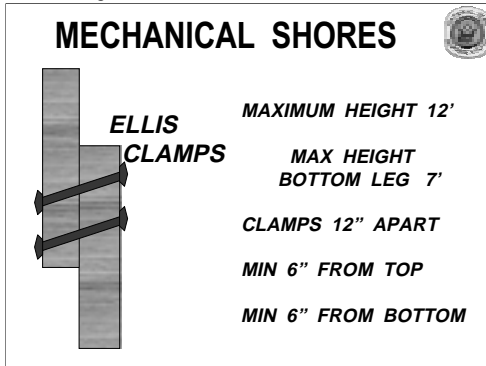

- Describe typical use of this item.
- Generally utilized only when the shoring material is too short.
- Working load is 6000 lbs, this does limit its uses.
- Shore must be assembled and properly pressurized with the Ellis jack.
- Clamps must be nailed in place.

Slide No. 89

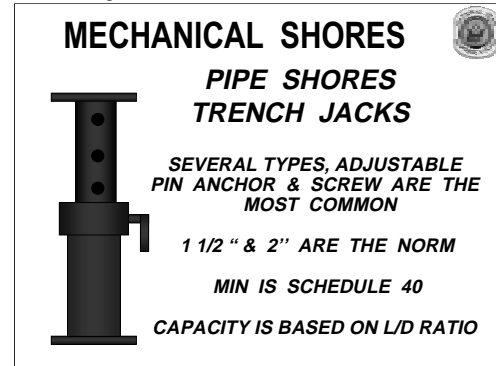

- Used in construction projects around the country, easily accessible.
- Various types and sizes available.
- Before using, check equipment's condition, many times the equipment has been abused.
- can be placed in position rather quickly.
- Not a permanent system, cannot be properly crossed braced.
- Use as initial shoring only, use wood sole & header.

Slide No. 90

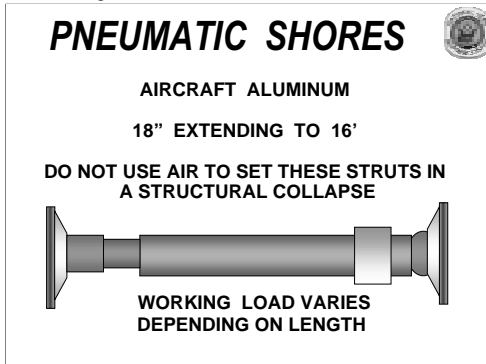

- There are two main types available explain both types.
- Accepted load ranges of the struts will be published in Struct Spec FOG.
- The longer the strut the lower the value (range 20,000 to 3,000 lbs).
- This are great for temporary support.
- At this time we don't have the capability to cross brace these items.
- Very strong, easy and quick to set up, great initial safety shoring.

Slide No. 91